

LIFEBUOY RELEASE SYSTEM - TECHNICAL PRODUCT SPECIFICATION AND INSTALLATION MANUAL

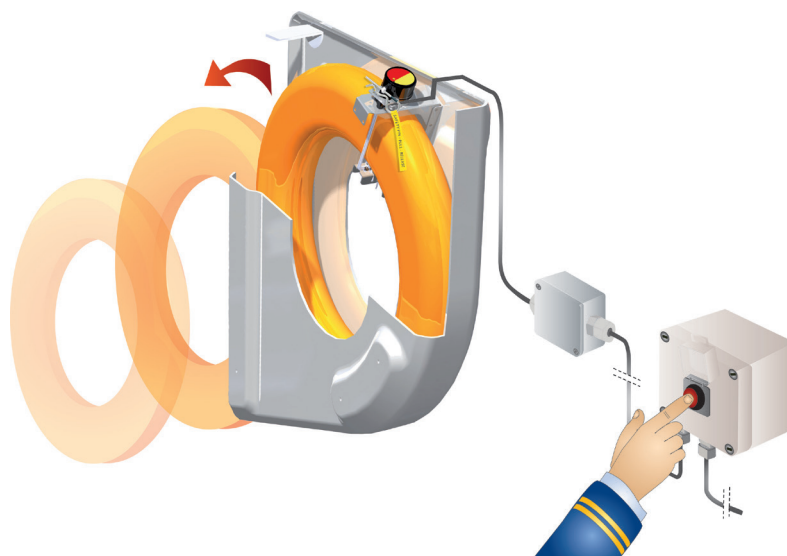

The LifeBuoy Remote Release System standard HM-0600 consists of the following parts:

- One GRP holder with pre-installed metal spring holder. The GRP holder can be mounted on port or starboard side of the ship and no change of the metal spring holder is needed. Measurements and hole positions - please check enclosed drawing.
- One ERU (electric remote unit) with cord pre-installed on the metal holder. The ERU cable is 1,5m long and shall be well strapped to the GRP holder in order to avoid any damage by weather or wind.
- One Release Switch in protective box to be mounted at the wheelhouse or bridge, IP66 class. Colour: silky grey. If mounted outside it shall be protected by an outer protective enclosure. Maximum diameter for cable 12mm. If the Release Switch shall be mounted flush in a bridge control panel please specify in the order - HM-0451 Release Switch for flush mounting. Measurements and hole position - please check enclosed drawing.
- One connector box in marine grade plastic, IP66 class. Colour: steel grey. Maximum diameter for cable 12mm. Measurements and hole positions - please check enclosed drawing.

- 20m cable from connector box to release switch, marine approved, screened 2 x 0,75mm², diameter 8mm. Longer lengths can be supplied on request by additional meter price. Maximum length of the installation is 150m. The Hammar products are designed to handle any voltage drop, so there is no need to increase the cable dimensions more than our recommendation.

Cable recommendations: 0 - 75m installation length - 2 x 0,75mm² and 75 - 150m installation length - 2 x 1,5mm².

Cables with a diameter larger than 12mm can not be handled in the cable glands and terminal blocks. Electric power required is 24VDC emergency power.

- One manual safety pin in stainless steel.
- One pilot line for loading the lifebuoy.
- Installation manual, user guide, marking instruction and test of the Lifebuoy Release System document.

Not supplied in the kit from CM Hammar:

- Lifebuoy (any SOLAS approved lifebuoy will fit the GRP holder)
- Mounting bolts and fittings for installation onboard.

Options available:

- HM-0610 LifeBuoy Release system, only manual release.
- HM-0650 LifeBuoy Release System, vacuum pump operated system.
- ATEX approved products are available, please contact CM Hammar for further information.

Spare parts:

- HM-0620 Lifebuoy metal spring holder only.
- HM-0630 Replacement kit for Lifebuoy System MkII, ERU electric/water activation with release cord and installation manual in English.
- HM-0660 Replacement kit for Lifebuoy System MkII, MRU vacuum operated with release cord and installation manual in English.
- HM-0406 Replacement kit for LifeBuoy System MkI, ERU electric/water activation with release cord, metal ring, cable tie and installation manual in English.



HM-0630



HM-0406



HM-0660

FAQ - Frequently Asked Questions:

- Can the GRP holder be mounted on either port or starboard side of the ship?

Yes, and no change of the metal holder is needed, but you will need mounting bolts and fittings for the installation.

- Can you connect an MOB Signal/ Smoke to the Hammar LifeBuoy System?

Yes, no problem to connect the MOB Signal/Smoke to the LifeBuoy System. Follow the instructions from the manufacturer of the MOB Signal/Smoke and make sure that the MOB Signal/Smoke can easily be pulled out from its holder.

- Is there a manual back-up?

Yes, you have a manual safety pin that can be pulled in order to release the lifebuoy.

FAQ - Frequently Asked Questions continued:

- Can there be an accidental release of the system in case of a cable being damaged or an earth fault?

No, there is no risk for an accidental release of the system.

- Can we test the function of the system?

Yes, you can test the system with any of the following methods:

- A/ Testing the mechanical release function – remove the manual safety pin holding the release cord, but make sure that the lifebuoy is securely lashed before the activation. Rearm the LifeBuoy System afterwards.

- B/ Testing the electronic remote release function – please check the enclosed document “Test of the Lifebuoy Release System”.

- C/ When the ERU is expired you can activate the ERU, but make sure that the lifebuoy is securely lashed before the activation. Rearm the LifeBuoy System afterwards.

HAMMAR LIFEBOUY RELEASE SYSTEM INSTALLATION MANUAL

Specification:

- One GRP holder with pre-installed metal holder and bracket.
- One ERU (electric remote unit) with cord pre-installed on metal holder.
- One Release Switch
- One Connector box
- 20m cable from connector box to release switch, screened 2 x 0,75mm², diameter 8mm
- One manual safety pin
- One pilot line for loading the lifebuoy
- Installation Manual, User Guide, Marking Instructions and Test of the Lifebuoy Release System

Not supplied in the kit from CM Hammar:

- Lifebuoy
- Mounting bolts and fittings for the installation onboard

Installation:

1. Mount the GRP holder in a position so that a released lifebuoy will easily fall into the water.
2. Follow the instructions for the mounting bolts in accordance with the pictures. Make sure that you mount double washers between frame or bulkhead and the GRP holder.

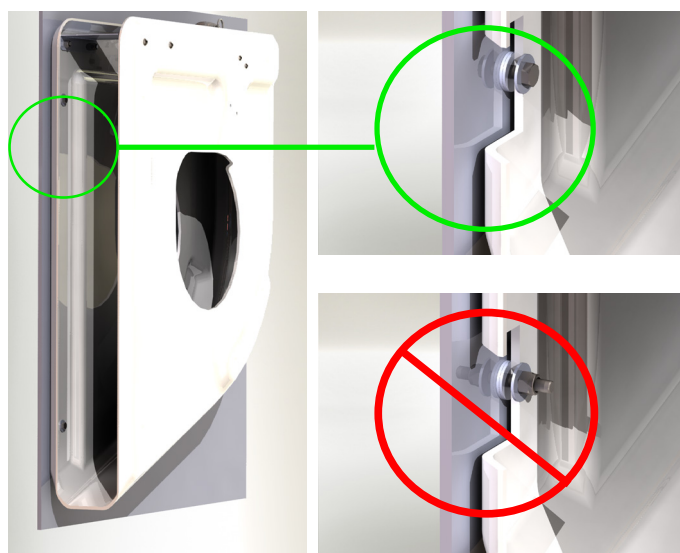

3. Mount the connector box close to the GRP holder. Make sure that the cable from the ERU is long enough to reach the connector box. The connector box shall be mounted with the cable glands horizontal in order to avoid water ingress. Always tighten the cable glands.



4. Mount the Release Switch in an easy to locate and manage position on the bridge. The Release Switch shall always be mounted inside the wheelhouse or bridge.



5. Install the screened cable from the connector box to the Release Switch and connect the black ERU cable to the connector box.



6. Connect 24V emergency power supply to the Release Switch. Ensure that you follow the enclosed connection drawing. Test the electrical installation according to instructions on the drawing or the enclosed document "Test of the Lifebuoy Release System".

7. The ERU is pre-installed. The ERU must be marked with its expiry date 2 years from installation onboard. Follow the enclosed marking instruction. An ERU, which is not properly marked with its date of expiry, is not approved.



8. Put a lifebuoy 2/3 into the GRP holder and then secure it for the installation phase. Use the supplied thin white pilot line to pull the release cord through the ERU unit. Make sure that the lifebuoy line is not on the outward side of the release cord! This might entangle the lifebuoy in an activation situation.

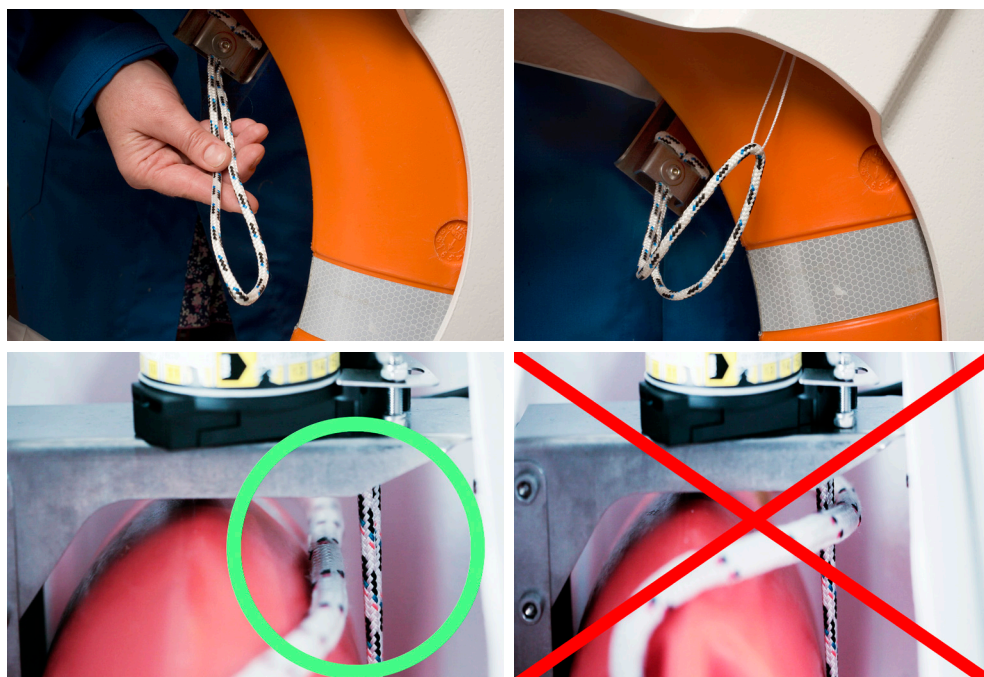

9. Pull up the release cord through the ERU hole with the pilot line. Secure it with the manual safety pin.



10. Connect the power to the Release Switch.
11. The safety cover on the Release Switch shall be secured with some kind of easy-to-break seal, in order to avoid unintentional use of the system.
12. The system is now ready for use. The ERU shall be changed after two years of service.

TEST OF THE LIFEBOUY RELEASE SYSTEM

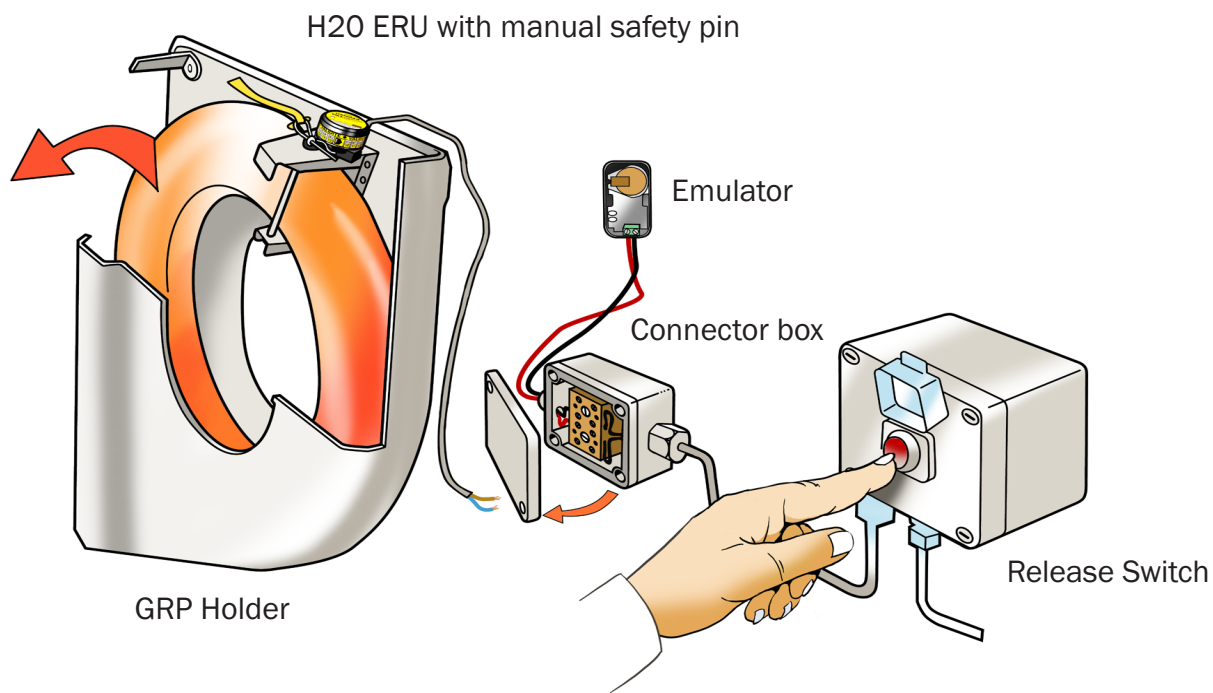

Instructions how to perform a test to assure functionality of the Lifebuoy Remote Release system

The test can be done in two steps; one mechanical and one electronic. The two different tests give a complete and sufficient functionality test of the system.

Testing the mechanical release function

1. Remove the manual safety pin holding the release cord.
2. The Lifebuoy will be released and launched from the GRP holder.



Testing the electronic remote release function by using the Emulator

1. Open the enclosure of the Emulator and attach two connection wires to the terminals on the Emulator. (Do not use too much torque on the terminal screws)
2. Push the push button on the circuit board to switch on the Emulator. The red and the green LED on the circuit board shall light up simultaneously. The green LED will start flashing green and the device is ready to be used.
3. Open the Connector box (mounted close to the GRP holder) and disconnect the flexible cable of the H20 ERU. Connect the two connection wires from the Emulator to the terminals on the Connector box, where the flexible cable was mounted. (The polarity is not important).

The Emulator can be left without observation mounted to the Connector box, as the Emulator will hold the indication of the LED turning from green to red if activated until the device is reset manually.

4. Push the Release Switch (should be mounted on the bridge or inside the wheelhouse) to activate the output of the Lifebuoy Release unit. The Emulator's LED will change from LED flashing green to LED flashing red if the output has been activated and the system is functional.

DO NOT FORGET TO RECONNECT THE H20 ERU AND THE SAFETY PIN AFTER THE TEST!

ERU EMULATOR - USER MANUAL

The ERU Emulator is a device designed to be used at installation and test of CM HAMMAR's ERRS Electronic Remote Release Systems.

With the Emulator it can be verified that an electric pulse sufficient to activate the HAMMAR H20 ERU Electric Release Unit is received at the connection point for the ERU Emulator.

The emulator measure and checks the current and the duration for the electric pulse and compare this with settings stored in the device.

Specification

Power supply	CR2032 (coin cell battery)
Operating time	Approx. 200 hours
Water ingress protection	No
Dimensions (L x H x D)	56 x 31 x 24 mm

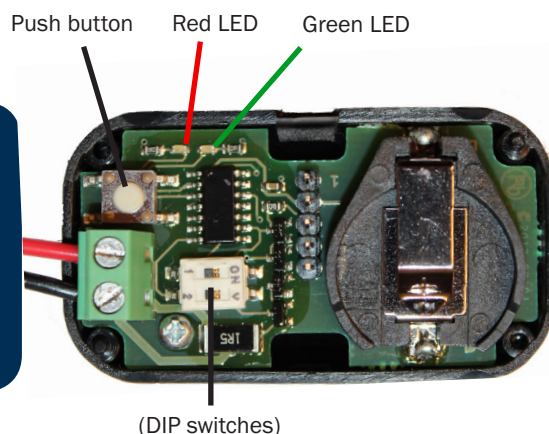

Instructions for use

First time of use

- Open the Emulator enclosure by gently twisting a screwdriver in the slot at the side of the enclosure.
- Insert a CR2032 battery in the battery holder.
- Attach two connection wires to the terminals on the Emulator. (Do not use too much torque on the terminal screws)

Normal use

- Open the enclosure and push the pushbutton on the circuit board to switch on the Emulator.

The red and the green LED on the circuit board shall light up simultaneously when the pushbutton is pushed. If the battery is ok the green LED will start flashing green and the device is ready to be used.

- Attach two connection wires to the terminals on the Emulator. (Do not use too much torque on the terminal screws)
- To test the system, connect the wires to the Electronic Remote Release System ERU output. (The polarity is not important)

If mounted on the circuit board the DIP switches are not used in this application and shall be in off position.

Test the Electronic Remote Release System

- Activate the output on the Electronic Remote Release System and check that the flashing green LED is turned off and that the red LED has started to flash.
- If the green LED is turned off and the red LED are turned on (flashing) the ERU output signal from the Electronic Remote Release System has been ok.

NB! The ERU Emulator does not break the circuit when it is activated and it will be detected as an installed ERU by the ERRS system even if it has turned from green to red.

Repeat the test

Push the pushbutton on the circuit to reset the Emulator. When the green LED is flashing, the device is ready to be used again.

To turn of the Emulator

- If a test has been performed, the Emulator has to be reset to a flashing green status.
- Then again push the pushbutton and the device will be turned off and the LED´s will stop flashing.

The device will turn itself off automatically 30 minutes from the last push on the pushbutton.

User guide		
Action		LED
Turn on the device	Push the button	Red and Green LED´s light up simultaneously
Reset the device after a test	Push the button	Red LED is turned off, Green LED starts flashing
Turn off the device	Push the button	Green LED is turned off
LED indications		
Emulator is operational (battery ok)		Green LED is flashing
Output has been activated		Green LED is turned off, Red LED is flashing
Low battery voltage on Emulator		Red and Green LED will give alternating flashes and the device will be switched off again.

GRP HOLDER DRAWING

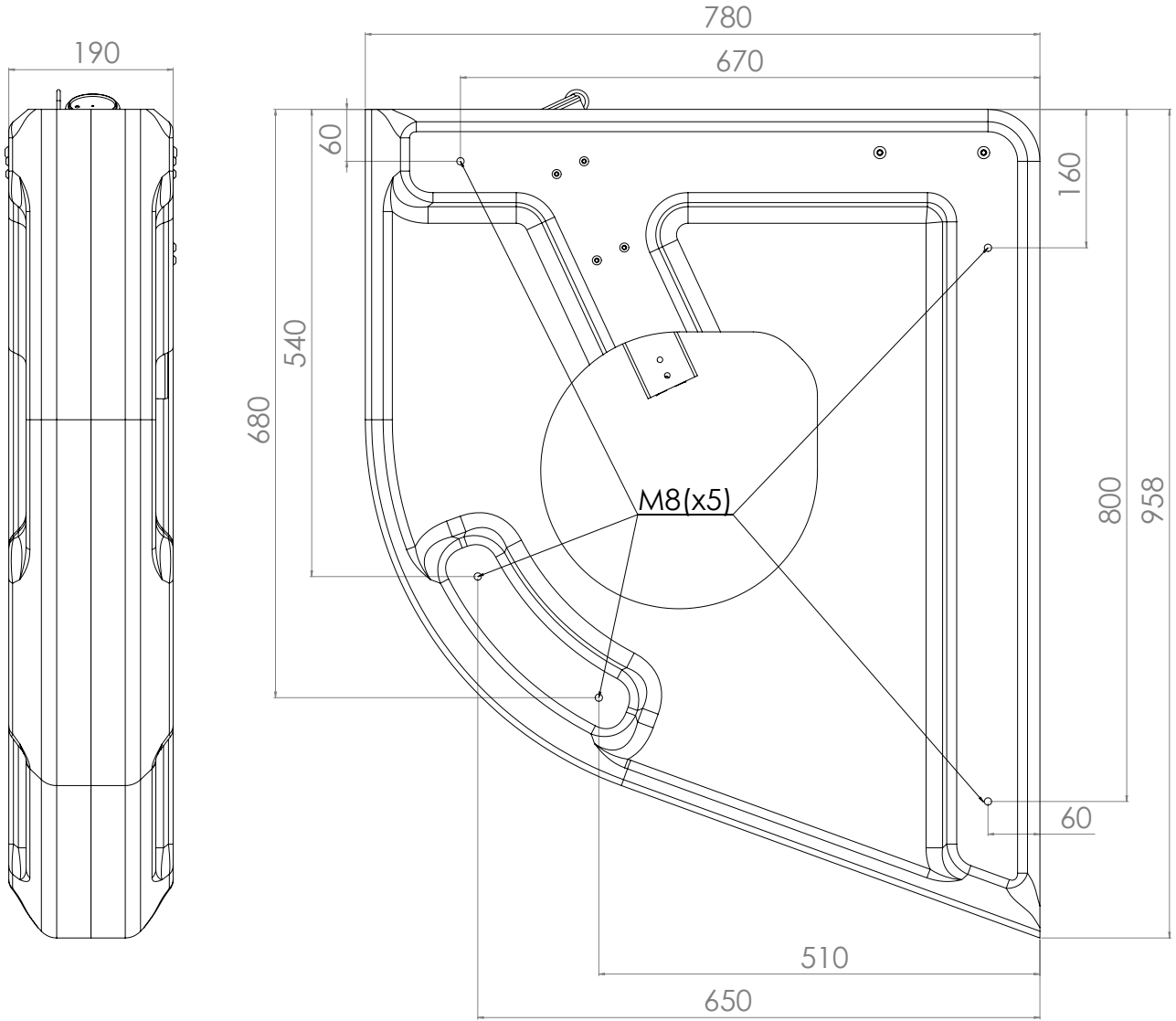

Sideview

Backview

Frontview

Topview



CONNECTOR BOX DRAWING

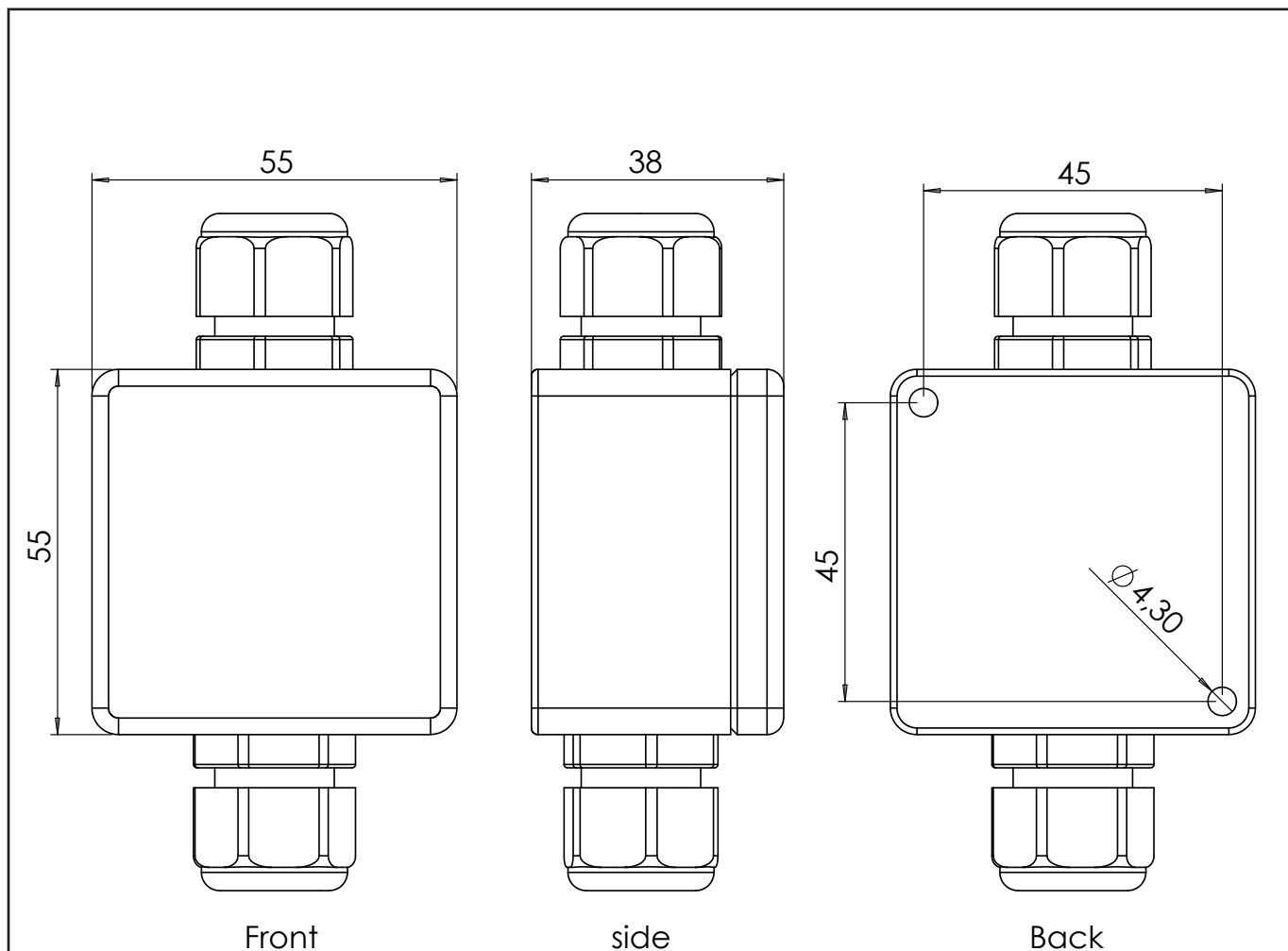

Det.	Number/ant.	Designation/benäm.		Material	Notes/noteringar
tor.c	tor.c	tor.c	1:1		10-07-2009
Drawn/Ritad	Checked/Kontr.	Appr./Godkänd	Scale/skala	Repl./Ersätter:	Date/Datum: (dd-mm-yyyy)
CM HAMMAR AB		CONNECTOR BOX ERU			Draw.No./Ritn.nr. A010007-01
Tel.: +46 31 709 65 50 Fax.: +46 31 49 70 23		Sheet 1 of 1			Rev.: 1

RELEASE SWITCH DRAWING

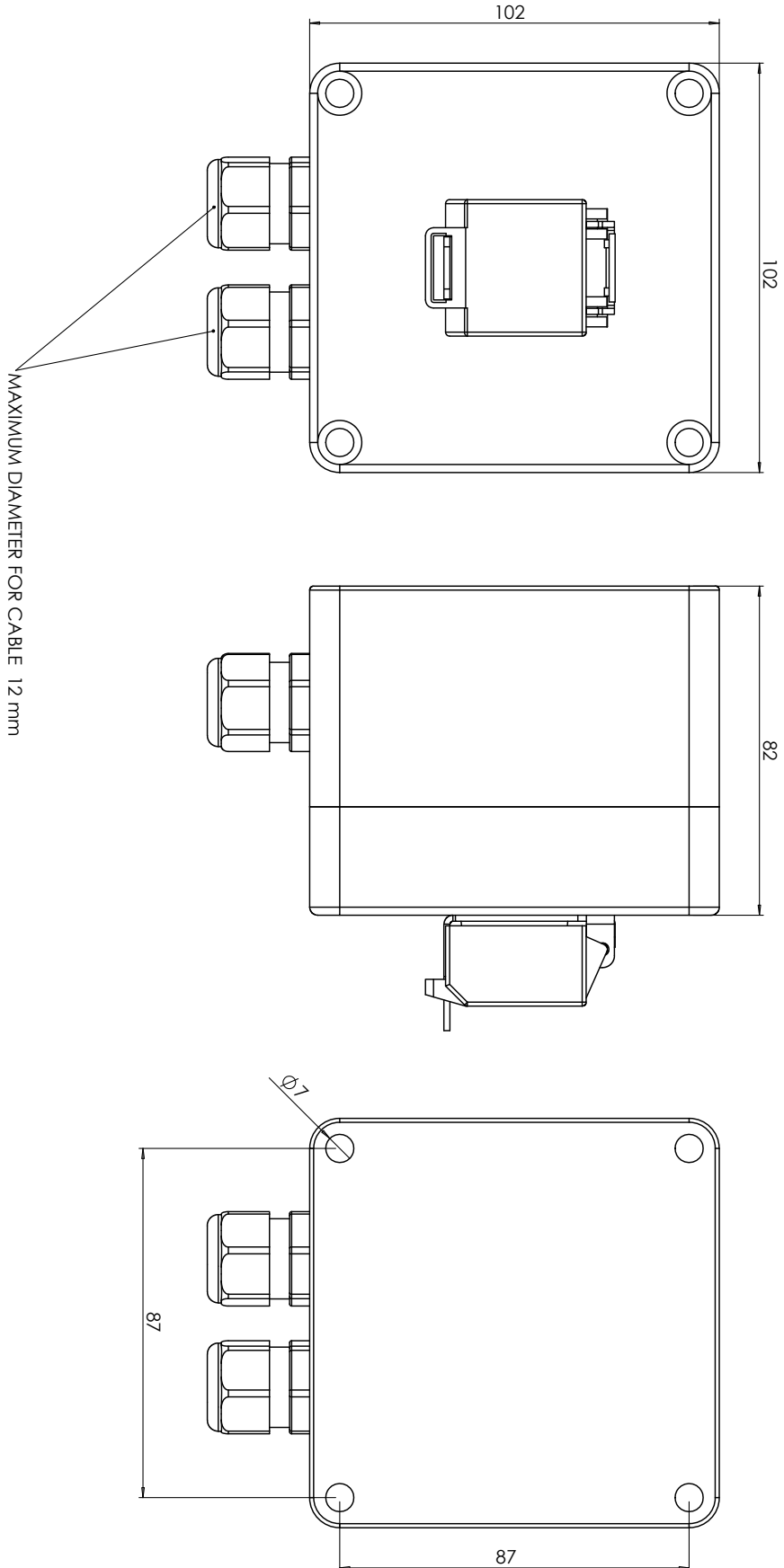

Del:	Number/omr:	Designation/beskrivning:	Material:	Notera/observera:
101.C	101.C	101.C		10-07-2009
Drawn/ritad:	Checked/kontrollerad:	Appr./godkänd:	Repl./ersätter:	Datera/Datum:
				Drawn/Ritad av:
CM HAMMAR AB			RELEASE SWITCH - DIMENSIONS	A010031
Tel.: +46 31 709 6550 Fax.: +46 31 487023			Sheet 1 of 1	Rev.: 1

WIRING CONNECTION DIAGRAM ERU

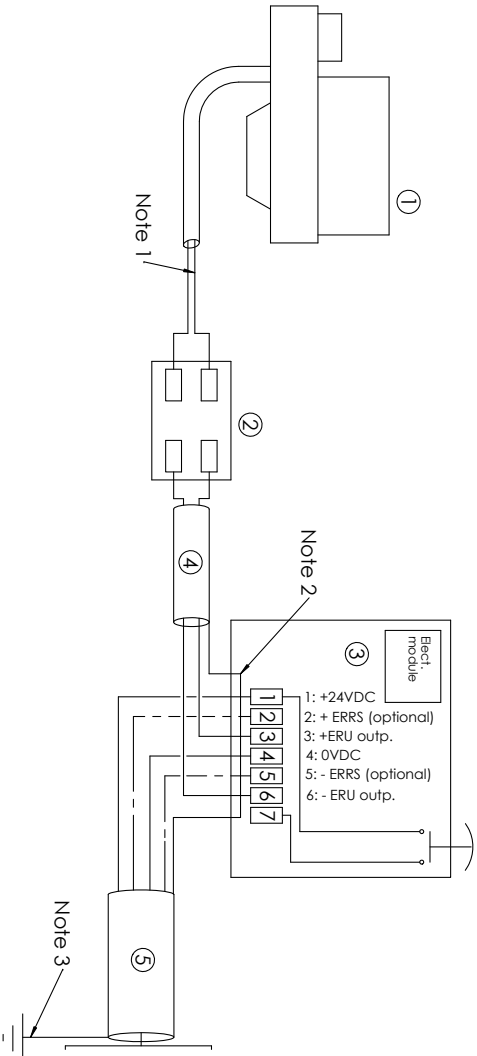

POWER SUPPLY, Terminal No:

- 1 to +24VDC EMERGENCY POWER SYSTEM
- 4 to 0VDC EMERGENCY POWER SYSTEM

Optional connection to ERRS system, Terminal No:

- 2 to + output ERRS system (upper terminals 1-10 in ERRS control box)
- 5 to - output ERRS system (lower terminals 1-10 in ERRS control box)

- POS 1: HAMMAR ELECTRIC RELEASE UNIT (H20 ERU)
 - POS 2: HAMMAR ERU CONNECTION BOX
Cable glands, max cable diameter 10 mm
Terminals: max cable area 2,5 mm²
 - POS 3: HAMMAR ERU RELEASE SWITCH with integrated push button
Input voltage 18VDC - 32VDC, Max. intermittent load 3A
Cable glands, max cable diameter 12 mm
Terminals: max cable area 2,5 mm²
 - POS 4: Cable, 2 x min. 0,75 mm² (screened). Outer diameter max. 10 mm
 - POS 5: Cable, 4 x min. 0,75 mm² (screened). Outer diameter max. 12 mm
or
Cable, 2 x min. 0,75 mm² (screened). Outer diameter max. 12 mm
- Note 1: When connecting the cable from the H20 -ERU to the CONNECTION BOX, the polarity of the wires is of no importance.
- Note 2: Connect the screen of the cables inside the Release switch enclosure
- Note 3: Connect the screen of the power supply cable to ships ground

TESTING THE INSTALLATION:
The correct function of the HAMMAR ERU RELEASE SWITCH can be tested by connecting a 200 mA F 5x20 mm glass tube fuse to the ERU RELEASE SWITCH output instead of the pos. 1 ERU unit. The fuse blows off when the ERU RELEASE SWITCH push button is pressed if the system is correctly installed.

Del:	Number/amt:	Designation/ber/dim.	Material	Notes/antingar
IC	IC	IC		03-10-2007
Drawn/Revised	Checked/draft:	Appr./Godkänd	Scale/skala	Date/datum (dd-mm-yyyy)
CM HAMMAR AB			Repl./ersätter:	Drawing/ritning
Tel: +46 31 709 65 50 Fax: +46 31 49 70 23				ERU1001
	Sheet of 1			Rev.: 7